

HeliCoil

Thread Repair & Thread Protection



**Screw Thread Inserts, Kits
& Components for Industrial
Maintenance, Repair and
Overhaul**

Bulletin 998

CERTIFIED
ISO 9001 • AS 9100
TS 16949 • ISO 14001

RIVTEC®
HELI-COIL®

The HELI-COIL Thread Repair System

STRIPPED

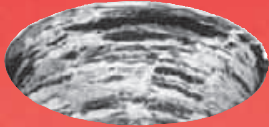

REPAIRED



When threads become stripped, worn or damaged for any reason, the strength and reliability are greatly reduced. Potentially dangerous situations are eliminated when the damaged thread is repaired with Heli-Coil screw thread inserts. The Heli-Coil threaded insert provides stronger, more reliable threads than the original tapped hole and at the same time eliminates the possibility of thread wear, seizing and corrosion.

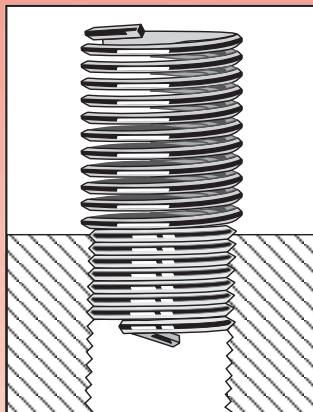

RETENTION PRINCIPLE

Heli-Coil inserts are larger in diameter before installation than the tapped hole. During installation the inserting tool tightens the insert which reduces the diameter of the leading coil so it can enter the tapped hole. After installation, each high tensile stainless steel coil expands outward against the tapped hole to permanently anchor the insert.

Heli-Coil has the most effective and universally accepted method of thread repair. Heli-Coil inserts quickly and permanently restore stripped, worn or damaged threads to their original size and condition.

Heli-Coil inserts work in any part or material – aluminum, magnesium, cast iron, bronze, etc. Increasing use of light weight (and soft) materials means more damage to threads. There is a Heli-Coil repair for virtually every application.

Damaged threads can be restored to better than new condition. The Heli-Coil system makes all other thread repair methods such as welding, plugging, oversized fasteners and over-

sized drilling of mating parts, obsolete. It's faster – you save time, increase your repair capabilities and restore parts that otherwise would have to be scrapped.

Stainless steel Heli-Coil inserts provide:

- Stronger Assemblies
- High Quality & Reliability
- Fastening Integrity Superior to the Original

Heli-Coil inserts eliminate:

- Thread Wear
- Corrosion
- Galling
- Rust

Heli-Coil inserts are precision formed coils of extremely hard stainless steel (18-8) diamond shaped wire. When installed into a Heli-Coil tapped hole, the insert provides permanent conventional screw-threads.

The insert has a driving "tang" for installation which is notched for easy removal.

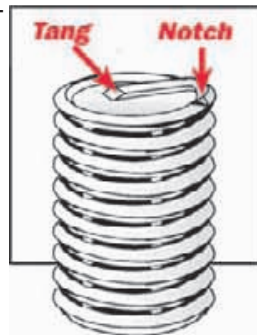

Heli-Coil inserts are also available with a "Screw-Locking" feature: a series of

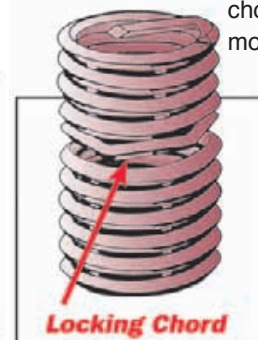

chords on one or more of the coils of the insert. They positively lock screws and bolts from loosening from impact or vibration.

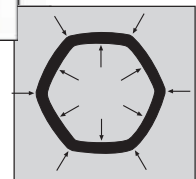
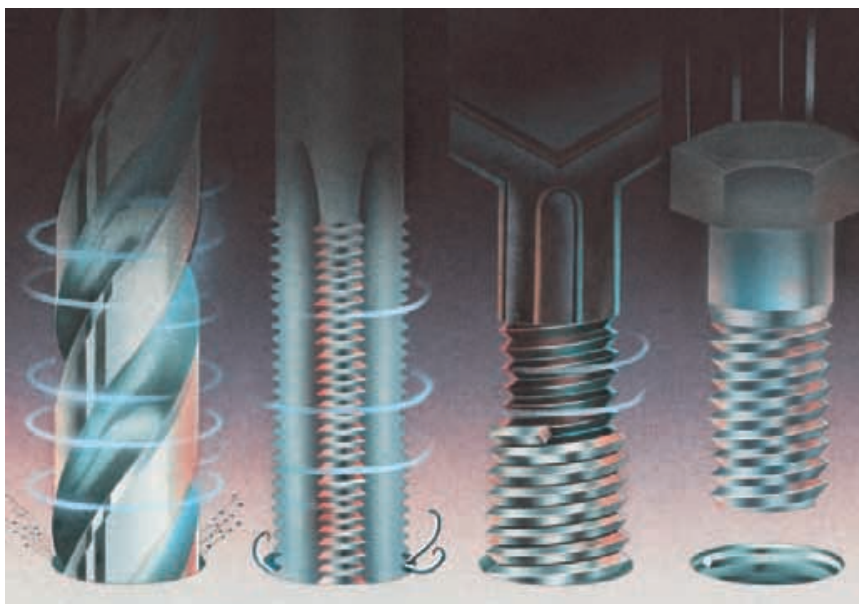

TABLE OF CONTENTS

The Heli-Coil Thread Repair System			
Introduction & Instructions	2 & 3	Drill-Out Kits & Tools	9
Inch Thread Repair Kits & Sets		Pipe Thread Kits	9
Professional Kits	4	Production Inserting Tools	10
Master Thread Repair Kits	4 & 5	Tang Break-Off & Extracting Tools	11
Master Thread Repair Sets	5	Bulk Inserts	
Metric Thread Repair Kits & Sets		Inch	12
Professional Kits	6	Bulk Inserts	
Master Thread Repair Kits	6 & 7	Metric, Spark Plug, Pipe Thread	13
Master Thread Repair Sets	7	Heli-Coil STI Taps	14
Spark Plug Series			
Spark Plug Inserts & Kits	8		
Sav-A-Thread Inserts & Kits	8		

The HELI-COIL Thread Repair System



Drill, Tap, Install... That's all!

DRILL

Drill out the damaged threads using the drill supplied in the kit. Drill to a sufficient depth to accommodate the insert length and the bolt or screw being used.

TAP

Tap the hole using the Heli-Coil tap supplied in the kit. Check the size on the shank of the tap to be sure it is the right size.

Tap the hole to sufficient depth to accommodate the insert length and bolt or screw being used.

INSTALL

Install the appropriate length insert from the kit. Use the installation tool supplied in the kit or set. Wind the insert into the hole until the top coil is 1/4 to 1/2 turn below the top surface.

TANG REMOVAL

Remove the tang by using the tang break-off rod (when supplied with the kit) or a punch which fits the inside of the insert. Place the punch or rod squarely on the tang and strike sharply.

For insert over 1/2 inch, 12mm, or for spark plug inserts, use long nose pliers. Holding the tang with the pliers, bend it alternately in and out until it comes free.

Note: For **Spark Plug** repairs, **NO** drilling is necessary. The Heli-Coil spark plug kit contains a piloted reamer tap. With this tap, the damaged threads are removed and new threads are cut in one continuous operation.

Tooling

HELI-COIL DRILLS

Heli-Coil High Speed Steel Drills are supplied in Master Thread Repair Sets (inch and metric) and all Thread Repair Kits except Spark Plug. All drills fit 1/2 inch chucks.

HELI-COIL TAPS

The taps supplied with kits and sets are referred to as STI or Screw Thread Insert taps. These taps must be used for Heli-Coil repairs.

The STI taps supplied for standard thread repair look like conventional taps and may be used with the same tap handle as conventional taps.

Taps for **Spark Plug** applications are known as a piloted reamer tap. These taps have a pilot thread at the front to pull the tap into the hole. The reamer section that follows removes the damaged threads and then the STI portion of the tap cuts the proper thread

for the insert. **No drilling is required with Heli-Coil spark plug taps.**

HELI-COIL INSTALLATION TOOLS

There are two types of Heli-Coil tools supplied in kits – threaded mandrel type and prewinder type. The prewinder tool is supplied in some coarse and all fine thread kits and sets. These inserts must be reduced in diameter before they are threaded into the tapped hole.

This is accomplished by winding the insert through a set of threads called a prewinder at the front of the tool. Generally, coarse thread inserts can be installed just as they come

from the package so a simple threaded mandrel type tool is supplied in the kit or set.



INCH Thread Repair Kits & Sets

PROFESSIONAL KITS

These kits include everything you need to do the job right – 3 lengths of inserts for multiple applications, drill, tap, installation tool and tang removal tool – all in a rugged new box.

Thread Size	Kit Part No.	Qty. Insert, Ea. Length	REPLACEMENT INSERTS			Tap	Installation Tool	Drill*	Tang* Removal Tool Size
			Short 1 Dia.	Medium 1-1/2 Dia.	Long 2 Dia.				
INCH COARSE									
4-40	5401-04	12	1185-04CN112	1185-04CN168	1185-04CN224	04CPB	2288-04	#31	5/64
5-40	5401-05	12	1185-05CN125	1185-05CN188	1185-05CN250	05CPB	7551-05	#29	3/32
6-32	5401-06	12	1185-06CN138	1185-06CN207	1185-06CN276	06CPB	2288-06	#25	3/32
8-32	5401-2	12	1185-2CN164	1185-2CN246	1185-2CN328	2CPB	2288-2	11/64	1/8
10-24	5401-3	12	1185-3CN190	1185-3CN285	1185-3CN380	3CPB	2288-3	13/64	1/8
12-24	5401-1	12	1185-1CN216	1185-1CN328	1185-1CN432	1CPB	2288-1	15/64	5/32
1/4-20	5401-4	12	1185-4CN250	1185-4CN375	1185-4CN500	4CPB	2288-4	17/64	3/16
5/16-18	5401-5	12	1185-5CN312	1185-5CN469	1185-5CN625	5CPB	2288-5	21/64	7/32
3/8-16	5401-6	6	1185-6CN375	1185-6CN562	1185-6CN750	6CPB	2288-6	25/64	9/32
7/16-14	5401-7	6	1185-7CN438	1185-7CN656	1185-7CN875	7CPB	2288-7	29/64	11/32
1/2-13	5401-8	6	1185-8CN500	1185-8CN750	1185-8CN1000	8CPB	2288-8	17/32	25/64
INCH FINE									
6-40	5402-06	12	1191-06CN138	1191-06CN207	1191-06CN276	06FPB	7552-6	#25	3/32
8-36	5402-2	12	1191-2CN164	1191-2CN246	1191-2CN328	2FPB	7552-2	#17	1/8
10-32	5402-3	12	1191-3CN190	1191-3CN285	1191-3CN380	3FPB	2299-3	13/64	1/8
1/4-28	5402-4	12	1191-4CN250	1191-4CN375	1191-4CN500	4FPB	2299-4	17/64	3/16
5/16-24	5402-5	12	1191-5CN312	1191-5CN469	1191-5CN625	5FPB	2299-5	21/64	7/32
3/8-24	5402-6	6	1191-6CN375	1191-6CN562	1191-6CN750	6FPB	2299-6	25/64	9/32
7/16-20	5402-7	6	1191-7CN438	1191-7CN656	1191-7CN875	7FPB	2299-7	29/64	11/32
1/2-20	5402-8	6	1191-8CN500	1191-8CN750	1191-8CN1000	8FPB	2299-8	33/64	25/64

*Not available as replacement kit components.

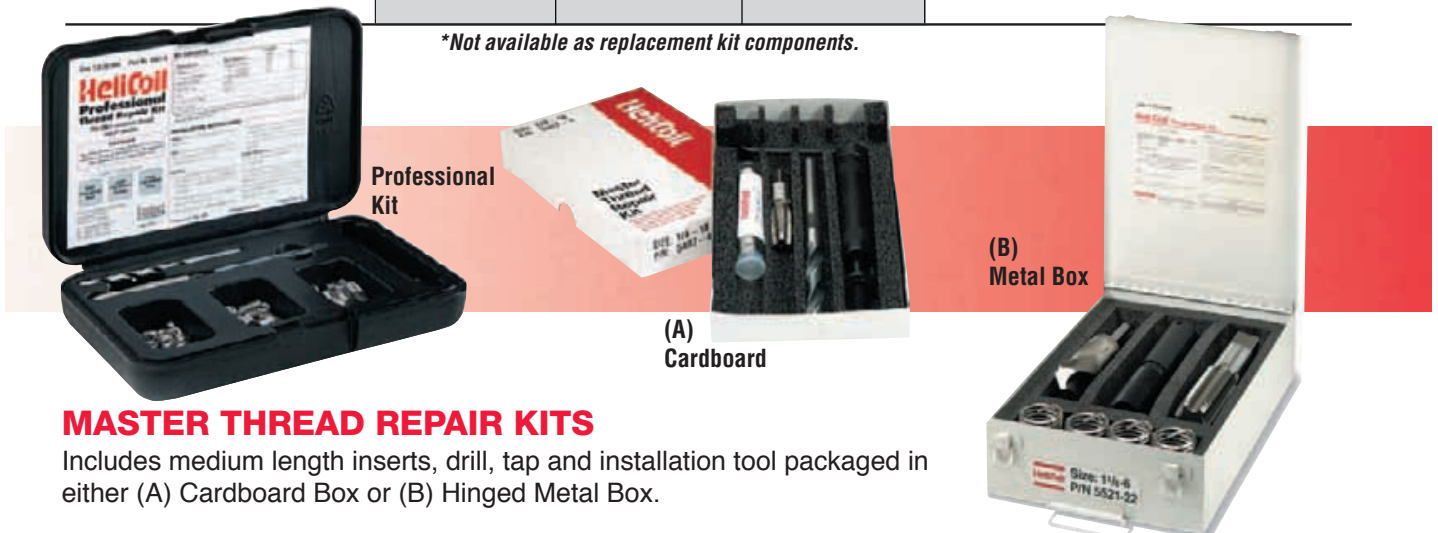

MASTER THREAD REPAIR KITS

Includes medium length inserts, drill, tap and installation tool packaged in either (A) Cardboard Box or (B) Hinged Metal Box.

Thread Size + Length	Kit Part No.	Inserts Per Kit	KIT CONTENTS & REPLACEMENT PARTS				Drill* Size	Box Style
			Tap Part No.	Installation Tool P/N	Insert Pkg. P./N	Insert Quantity		
INCH COARSE								
9/16-12 x .844	5401-9	6	187-9	2288-9	R1185-9	6	19/32	A
5/8-11 x .938	5401-10	6	8187-10	2288-10	R1185-10	6	21/32	A
3/4-10 x 1.125	5401-12	4	8187-12	2288-12	R1185-12	4	25/32	A

*Drills not available as replacement kit components.

INCH Thread Repair Kits & Sets

MASTER THREAD REPAIR KITS (cont'd)

Thread Size + Length	Kit Part No.	Inserts Per Kit	KIT CONTENTS & REPLACEMENT PARTS				Drill* Size	Box Style
			Tap Part No.	Installation Tool P/N	Insert Pkg. P/N	Insert Quantity		
INCH COARSE								
7/8-9 x 1.312	5521-14	6	8187-14	3724-14	K1185-14	1	29/32	B
1-8 x 1.500	5521-16	6	8187-16	3724-16	K1185-16	1	1 1/32	B
1 1/8-7 x 1.688	5521-18	5	8187-18	3724-18	K1185-18	1	1 5/32	B
1 1/4-7 x 1.875	5521-20	4	8187-20	3724-20	K1185-20	1	1 9/32	B
1 3/8-6 x 2.062	5521-22	4	8187-22	3724-22	K1185-22	1	1 13/32	B
1 1/2-6 x 2.250	5521-24	4	8187-24	3724-24	K1185-24	1	1 17/32	B
INCH FINE								
9/16-18 x .844	5402-9	6	38193-9	2299-9	R1191-9	6	37/64	A
5/8-18 x .938	5402-10	6	8193-10	2299-10	R1191-10	6	41/64	A
3/4-16 x 1.125	5402-12	4	8193-12	2299-12	R1191-12	4	49/64	A
7/8-14 x 1.312	5528-14	6	8193-14	535-14	K1191-14	1	57/64	B
1-14 x 1.500	5528-16	6	8193-16	535-16	K1191-16	1	1 1/64	B
1-12 x 1.500	5528-161	6	8193-161	535-161	K1191-161	1	1 1/64	B
1 1/8-12 x 1.688	5528-18	5	8193-18	535-18	K1191-18	1	1 5/32	B
1 1/4-12 x 1.875	5528-20	4	8193-20	535-20	K1191-20	1	1 9/32	B
1 3/8-12 x 2.062	5528-22	4	8193-22	535-22	K1191-22	1	1 17/32	B
1 1/2-12 x 2.250	5528-24	4	8193-24	535-24	K1191-24	1	1 17/32	B

*Drills not available as replacement kit components.

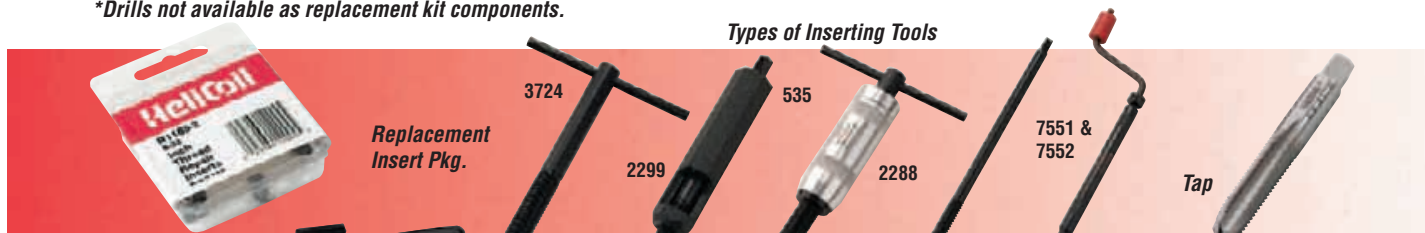

MASTER THREAD REPAIR SETS

Thread Size + Length	Insert Pkg. P/N	Insert Qty.	Tap P/N	Drill* Size	Installation Tool P/N
PART NO. 4934 – CONTENTS					
1/4-20 x .375	R1185-4	12	4CPB	17/64	2288-4
5/16-18 X .469	R1185-5	12	5CPB	21/64	2288-5
3/8-16 X .562	R1185-6	12	6CPB	25/64	2288-6
7/16-14 X .656	R1185-7	6	7CPB	29/64	2288-7
1/2-13 X .750	R1185-8	6	8CPB	17/32	2288-8
5/8-11 X .938	R1185-10	6	8187-10	21/32	2288-10
PART NO. 4936 – CONTENTS					
10-32 x .285	R1191-3	12	3FPB	13/64	2299-3
1/4-28 X .375	R1191-4	12	4FPB	17/64	2299-4
5/16-24 X .469	R1191-5	12	5FPB	21/64	2299-5
3/8-24 X .562	R1191-6	12	6FPB	25/64	2299-6
7/16-20 X .656	R1191-7	6	7FPB	29/64	2299-7
1/2-20 X .750	R1191-8	6	8FPB	33/64	2299-8

*Drills not available as replacement kit components.

METRIC Thread Repair Kits & Sets

PROFESSIONAL KITS

These kits include everything you need to do the job right – 3 lengths of inserts for multiple applications, drill, tap, installation tool and tang removal tool – all in a rugged new box.

Thread Size	Kit Part No.	Qty/Insert Each Length	REPLACEMENT INSERTS			Tap	Installation Tool	Tool Style	Drill*	Tang* Removal Tool Size
			Short 1 Dia.	Medium 1-1/2 Dia.	Long 2 Dia.					
METRIC COARSE										
M3x0.5	5403-3	12	1084-3CN030	1084-3CN045	1084-3CN060	2087-3	7751-3	A	1/8	3/32
M3.5x0.6	5403-3.5	12	1084-3.5CN035	1084-3.5CN053	1084-3.5CN070	2087-3.5	7751-3.5	A	#27	3/32
M4x0.7	5403-4	6	1084-4CN040	1084-4CN060	1084-4CN080	2087-4	3747-4	B	11/64	1/8
M5x0.8	5403-5	6	1084-5CN050	1084-5CN075	1084-5CN100	2087-5	3747-5	B	13/64	5/32
M6x1	5403-6	6	1084-6CN060	1084-6CN090	1084-6CN120	2087-6	3747-6	B	1/4	3/16
M7x1	5403-7	6	1084-7CN070	1084-7CN105	1084-7CN140	2087-7	3747-7	C	9/32	7/32
M8x1.25	5403-8	6	1084-8CN080	1084-8CN120	1084-8CN160	2087-8	3747-8	C	21/64	7/32
M10x1.5	5403-10	6	1084-10CN100	1084-10CN150	1084-10CN200	2087-10	3747-10	C	13/32	9/32
M12x1.75	5403-12	6	1084-12CN120	1084-12CN180	1084-12CN240	2087-12	3747-12	C	31/64	25/64
METRIC FINE										
M8x1	5404-8	6	4255-8CN080	4255-8CN120	4255-8CN160	4984-8	4835-8	B	21/64	7/32
M10x1	5404-10	6	4255-10CN100	4255-10CN150	4255-10CN200	4984-10	4835-10	B	13/32	9/32
M10x1.25	5405-10	6	4649-10CN100	4649-10CN150	4649-10CN200	4944-10	4640-10	B	13/32	9/32
M12x1.25	5405-12	6	4649-12CN120	4549-12CN180	4649-12CN240	4944-12	4640-12	B	31/64	25/64
M12x1.5	5406-12	6	3745-12CN120	3745-12CN180	3745-12CN240	4976-12	4973-12	B	31/64	25/64

* Not available as replacement kit components.



MASTER THREAD REPAIR KITS

Includes medium length inserts, drill, tap and installation tool packed in a durable cardboard box.

Thread Size	Length	Kit Part No.	Inserts Per Kit	KIT CONTENTS & REPLACEMENT PARTS					Drill* Size	
				Tap Part No.	Installation Tool P/N	Tool Style	Insert Pkg. P/N	Insert Quantity		
METRIC COARSE										
M14x2	21.0	5403-14	12	2087-14	3747-14	C	R1084-14	6	37/64	
M16x2	24.0	5403-16	6	2087-16	3747-16	C	R1084-16	6	21/32	
M18x2.5	27.0	5403-18	6	2087-18	3747-18	C	R1084-18	6	47/64	
M20x2.5	30.0	5403-20	4	2087-20	3747-20	C	K1084-20	3	13/16	

* Drills not available as replacement kit components.

METRIC Thread Repair Kits & Sets

THREAD REPAIR KIT (cont'd)

Thread Size	Length	Kit Part No.	Inserts Per Kit	KIT CONTENTS & REPLACEMENT PARTS					Drill* Size
				Tap Part No.	Installation Tool P/N	Tool Style	Insert Pkg. P/N	Insert Quantity	
METRIC COARSE									
M14x1.5	21.0	5406-14	12	4976-14	4973-14	D	R3745-14	6	9/16
M16x1.5	24.0	5406-16	6	4976-16	4973-16	D	R3745-16	6	21/32
M18x1.5	27.0	5406-18	6	4976-18	4973-18	D	R3745-18	6	23/32

* Drills not available as replacement kit components.

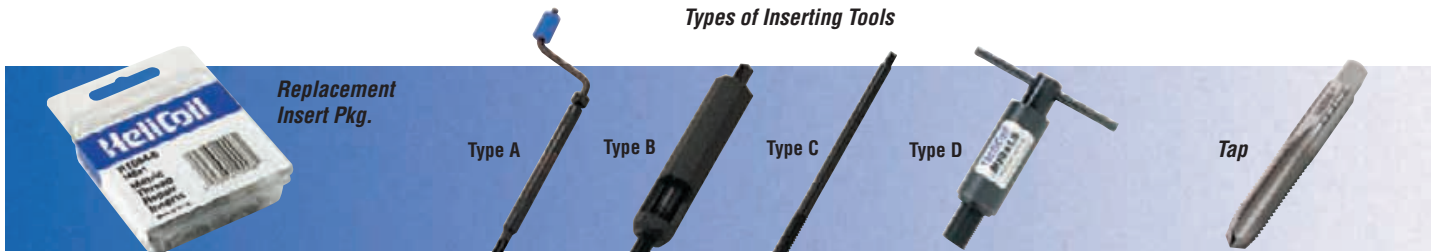

These sets contain repairs for the most commonly used thread sizes. Two sets are available, part number 4937-150 which contains sizes M5, M6, M8 and M10x1.5 and part number 4937-125 which contains M5, M6, M8 and M10x1.25. Each set has a drill bit, tap, installation tool, a quantity of inserts for each size and complete instructions.

MASTER THREAD REPAIR SETS

Thread Size	Length	Insert Pkg. P/N	Insert Qty.	Tap P/N	Installation Tool P/N	Tool Style	Drill* Size
PART NO. 4937-150 – CONTENTS							
M5 x 0.8	7.5	R1084-5	12	2087-5	3747-5	B	13/64
M6 x 1	9.0	R1084-6	12	2087-6	3747-6	B	1/4
M8 x 1.25	12.0	R1084-8	12	2087-8	3747-8	C	21/64
M10 x 1.5	15.0	R1084-10	12	2087-10	3747-10	C	13/32
PART NO. 4937-125 – CONTENTS							
M5 x 0.8	7.5	R1084-5	12	2087-5	3747-5	B	13/64
M6 x 1	9.0	R1084-6	12	2087-6	3747-6	B	1/4
M8 x 1.25	12.0	R1084-8	12	2087-8	3747-8	C	21/64
M10 x 1.25	15.0	R4649-10	12	4944-10	4640-10	B	3/32

* Drills not available as replacement kit components.

SPARK PLUG Series

SPARK PLUG

Heli-Coil is the original spark plug port thread repair. These kits offer the highest quality and most durable repair available. The first choice of professional mechanics and engine rebuilders, Heli-Coil Wire Spark Plug Inserts are available for any engine. Kits are available in sizes M10, M12, M14, M18, and 7/8". Each kit contains a piloted tap (no drilling necessary), an installation tool, and a quantity of inserts. The M12 and M14 kits contain several insert lengths to accommodate all spark plug reaches. Heli-Coil Spark Plug Inserts are the preferred method of repair specified by virtually all U.S. and foreign vehicle manufacturers.



KIT CONTENTS AND REPLACEMENT PARTS

Thread Size	Reach	Kit Part No.	Inserts Per Kit	Tap Part No.	Installation Tool Part No.	Reach	Insert Pkg. Pack No.	Insert Quantity
10-1.0mm	1/2"	5523-10	24	1030-10	4971-10	1/2"	R474-4	6
12-1.25mm	1/2"	5523-12	12	1030-12	4971-12	1/2"	R482-1	6
	3/4"		12			3/4"	R482-2	6
14-1.25mm	3/8"	5523-14	6	1030-14	4971-14	3/8"	R512	6
	7/16"		6			7/16"	R513	6
	1/2"		6			1/2"	R513-13	6
	3/4"		6			3/4"	R513-10	6
	.472"		6			.472"	R513-20	6
18-1.50mm	1/2"	5523-18	24	1030-18	4971-18	1/2"	R514-6	6
7/8-18	1/2"-5/8"	550	10	549	548	1/2"-5/8"	K518-12	5

Do **NOT** use Heli-Coil wire inserts to repair taper seat spark plug ports.



SAV-A-THREAD

The only thread repair product that can be used to repair both taperseat and gasket type spark plug assemblies. Sav-A-Thread is the easiest way to permanently repair stripped spark plug hole threads.

- Three insert lengths are available to accommodate all spark plug reaches.
- Positive mechanical locking feature means the insert will never come out!
- The piloted reamer tap means no drilling is necessary and perfect alignment of the tapped hole is attained.

PART NO. 5408-14

KIT CONTENTS AND REPLACEMENT PARTS

Size	Part No.	Reach	Insert Per Kit	Tap Part No.	Installation Tool Part No.	Insert Pkg. Part No.	Pkg. Insert Qty.
M14x1.25	5408-14	Short	6	5329-14	5332-14	R5326-14S-6	6
		Normal	6			R5326-14N-6	6
		Long	6			R5326-14L-6	6

Note: Heli-Coil recommends removing the head before installation to insure chips do not enter cylinder.

PRODUCTION Inserting Tools



The various designs of Heli-Coil inserting tools are pictured left. Generally, finer pitch inserts are proportionately larger in the free state than coarse pitch inserts and thus have to be “pre-wound” to a smaller diameter for installation. Large coarse pitch inserts (and 2-56 and 3-48 inserts) need only a threaded mandrel tool for installation.

INCH SERIES					
Size	Part No.	Style	Size	Part No.	Style
UNIFIED COARSE			UNIFIED FINE		
2-56	551-02	1	3-56	7552-03	2
3-48	551-03	–	4-48	7552-04	2
4-40	7551-04	2	6-40	7552-06	2
5-40	7551-05	2	8-36	7552-2	2
6-32	7551-06	2	10-32	7552-3	2
8-32	7551-2	2	1/4-28	7552-4	2
10-24	7551-3	2	5/16-24	7552-5	2
12-24	7551-1	2	3/8-24	7552-6	2
1/4-20	7551-4	2	7/16-20	7552-7	2
5/16-18	7551-5	2	1/2-20	7552-8	2
3/8-16	7551-6	2	9/16-18	535-9	4
7/16-14	7551-7	2	5/8-18	535-10	4
1/2-13	7551-8	2	3/4-16	535-12	4
9/16-12	3724-9	3	7/8-14	535-14	4
5/8-11	3724-10	3	1-12	535-161	4
3/4-10	3724-12	3	1-14	535-16	4
7/8-9	3724-14	3	1-1/8-12	535-18	4
1-8	3724-16	3	1-1/4-12	535-20	4
1-1/8-7	3724-18	3	1-3/8-12	535-22	4
1-1/4-7	3724-20	3	1-1/2-12	535-24	4
1-3/8-6	3724-22	3			
1-1/2-6	3724-24	3			
METRIC SERIES					
METRIC COARSE			METRIC FINE		
M2.2x0.45	7751-2.2	1	M8x1	7755-8	2
M2.5x0.45	7751-2.5	2	M10x1	7755-10	2
M3x0.5	7751-3	2	M10x1.25	7756-10	2
M3.5x0.6	7751-3.5	2	M12x1.25	7756-12	2
M4x0.7	7751-4	2	M12x1.5	7753-12	2
M5x0.8	7751-5	2	M14x1.5	7753-14	4
M6x1	7751-6	2	M16x1.5	7753-16	4
M7x1	7751-7	2	M18x1.5	7753-18	4
M8x1.25	7751-8	2			
M10x1.5	7751-10	2			
M12x1.75	7751-12	2			
M14x2	7751-14	4			
M16x2	7751-16	4			
M18x2.5	7751-18	4			
M20x2.5	7751-20	4			
M22x2.5	7751-22	3			
M24x3	7751-24	3			

Tang Break-Off and Extracting Tools



Tang Break-Off Tools

Extracting Tool

EXTRACTING TOOL POSITION

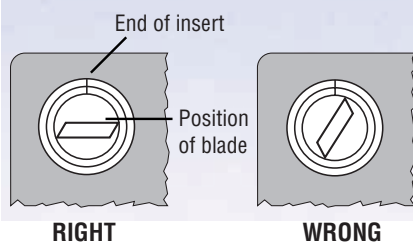

RIGHT

WRONG

TANG BREAK-OFF TOOLS

The driving tangs of Heli-Coil Inserts must be removed to eliminate their interference with the end of the assembled bolt. Tang Break-Off Tools are available for use with inserts through 1/2" and M12 nominal diameter. Their operation is automatic, having a spring loaded, easily triggered punch that strikes a sharp, uniform blow against the tang of the installed insert.

INCH SERIES			
Size	Part No.	Size	Part No.
UNIFIED FINE		UNIFIED FINE	
2-56	3695-02	3-56	3695-02
3-48	3695-02	4-48	3695-04
4-40	3695-04	6-40	3695-06
5-40	3695-04	8-36	3695-2
6-32	3695-06	10-32	3695-3
8-32	3695-2	1/4-28	3695-4
10-24	3695-3	5/16-24	3692-5
12-24	3695-3	3/8-24	3692-6
1/4-20	3695-4	7/16-20	3692-7
5/16-18	3695-5	1/2-20	3692-8
3/8-16	3695-6		
7/16-14	3695-7		
1/2-13	3695-8		
METRIC SERIES			
METRIC COARSE			
M2.2	4238-2.2		
M2.5	4238-2.2		
M3	4238-3		
M3.5	4238-3		
M4	4238-4		
M5	4238-5		
M6	4238-6		
M7	4238-7		
M8	4238-8		
M10	4238-10		
M12	4238-12		

For sizes above 1/2" and 12mm use long nose pliers.

EXTRACTING TOOLS

Tools to remove Heli-Coil inserts are listed below. This is done by applying the tool to the insert (see illustration at left), striking the head of the tool a light blow and turning it counterclockwise, maintaining steady downward pressure.

INCH SERIES		METRIC SERIES	
Nominal Size	Part No.	Nominal Size	Part No.
#2	1227-02	M2.2	1227-02
#3 thru #8	1227-06	M2.5 thr M4.5	1227-06
#10 thru 3/8"	1227-6	M5 thru M10	1227-6
7/17" thru 1"	1227-16	M11 thru M24	1227-16
1-1/8" thru 1-1/2"	1227-24	M27 thru M39	1227-24

For sizes above 12" use long nose pliers.

BULK Inserts

FREE RUNNING – INCH

SCREW-LOCK – INCH

Size + Length	Part No.	Size + Length	Part No.	Size + Length	Part No.	Size + Length	Part No.
2-56 { 086 129 172	1185-02CN086 1185-02CN129 1185-02CN172	1/2-13 { 500 750 1000	1185-8CN500 1185-8CN750 1185-8CN1000	2-56 { 086 129 172	3585-02CN086 3585-02CN129 3585-02CN172	5/16-24 { 312 469 625	3591-5CN312 3591-5CN469 3591-5CN625
3-48 { 099 148 198	1185-03CN099 1185-03CN148 1185-03CN198	1/2-20 { 500 750 1000	1191-8CN 500 1191-8CN750 1191-8CN1000	3-48 { 099 148 198	3585-03CN099 3585-03CN148 3585-03CN198	3/8-16 { 375 562 750	3585-6CN375 3585-6CN562 3585-6CN750
3-56 { 099 148 198	1191-03CN099 1191-03CN148 1191-03CN198	9/16-12 { 562 844 1125	1185-9CN562 1185-9CN844 1185-9CN1125	3-56 { 099 148 198	3591-03CN099 3591-03CN148 3591-03CN198	3/8-24 { 375 562 750	3591-6CN375 3591-6CN562 3591-6CN750
4-40 { 112 168 224	1185-04CN112 1185-04CN168 1185-04CN224	9/16-18 { 562 844 1125	1191-9CN562 1191-9CN844 1191-9CN1125	4-40 { 112 168 224	3585-04CN112 3585-04CN168 3585-04CN224	7/16-14 { 438 656 875	3585-7CN438 3585-7CN656 3585-7CN875
4-48 { 112 168 224	1191-04CN112 1191-04CN168 1191-04CN224	5/8-11 { 625 938 1250	1185-10CN625 1185-10CN938 1185-10CN1250	4-48 { 112 168 224	3591-04CN112 3591-04CN168 3591-04CN224	7/16-20 { 438 656 875	3591-7CN438 3591-7CN656 3591-7CN875
5-40 { 125 188 250	1185-05CN125 1185-05CN188 1185-05CN250	5/8-18 { 625 938 1250	1191-10CN625 1191-10CN938 1191-10CN1250	5-40 { 125 188 250	3585-05CN125 3585-05CN188 3585-05CN250	1/2-13 { 500 750 1000	3585-8CN500 3585-8CN750 3585-8CN1000
6-32 { 138 207 276	1185-06CN138 1185-06CN207 1185-06CN276	3/4-10 { 750 1125 1500	1185-12CN750 1185-12CN1125 1185-12CN1500	6-32 { 138 207 276	3585-06CN138 3585-06CN207 3585-06CN276	1/2-20 { 500 750 1000	3591-8CN 500 3591-8CN750 3591-8CN1000
6-40 { 138 207 276	1191-06CN138 1191-06CN207 1191-06CN276	3/4-16 { 750 1125 1500	1191-12CN750 1191-12CN1125 1191-12CN1500	6-40 { 138 207 276	3591-06CN138 3591-06CN207 3591-06CN276	9/16-12 { 562 844 1125	3585-9CN562 3585-9CN844 3585-9CN1125
8-32 { 164 246 328	1185-2CN164 1185-2CN246 1185-2CN328	7/8-9 { 875 1312 1750	1185-14CN875 1185-14CN1312 1185-14CN1750	8-32 { 164 246 328	3585-2CN164 3585-2CN246 3585-2CN328	9/16-18 { 562 844 1125	3591-9CN562 3591-9CN844 3591-9CN1125
8-36 { 164 246 328	1191-2CN164 1191-2CN246 1191-2CN328	7/8-14 { 875 1312 1750	1191-14CN875 1191-14CN1312 1191-14CN1750	8-36 { 164 246 328	3591-2CN164 3591-2CN246 3591-2CN328	5/8-11 { 625 938 1250	3585-10CN625 3585-10CN938 3585-10CN1250
10-24 { 190 285 380	1185-3CN190 1185-3CN285 1185-3CN380	1-8 { 1000 1500 2000	1185-16CN1000 1185-16CN1500 1185-16CN2000	10-24 { 190 285 380	3585-3CN190 3585-3CN285 3585-3CN380	5/8-18 { 625 938 1250	3591-10CN625 3591-10CN938 3591-10CN1250
10-32 { 190 285 380	1191-3CN190 1191-3CN285 1191-3CN380	1-14 { 1000 1500 2000	1191-16CN1000 1191-16CN1500 1191-16CN2000	10-32 { 190 285 380	3591-3CN190 3591-3CN285 3591-3CN380	3/4-10 { 750 1125 1500	3585-12CN750 3585-12CN1125 3585-12CN1500
12-24 { 216 324 432	1185-1CN216 1185-1CN324 1185-1CN432	1-12 { 1000 1500 2000	1191-161CN1000 1191-161CN1500 1191-161CN2000	12-24 { 216 324 432	3585-1CN216 3585-1CN324 3585-1CN432	3/4-18 { 750 1125 1500	3591-12CN750 3591-12CN1125 3591-12CN1500
1/4-20 { 250 375 500	1185-4CN250 1185-4CN375 1185-4CN500	1-1/8-7 { 1125 1688 2250	1185-18CN1125 1185-18CN1688 1185-18CN2250	1/4-20 { 250 375 500	3585-4CN250 3585-4CN375 3585-4CN500	7/8-9 { 875 1312 1750	3585-14CN875 3585-14CN1312 3585-14CN1750
1/4-28 { 250 375 500	1191-4CN250 1191-4CN375 1191-4CN500	1-1/8-12 { 1125 1688 2250	1191-18CN1125 1191-18CN1688 1191-18CN2250	1/4-28 { 250 375 500	3591-4CN250 3591-4CN375 3591-4CN500	7/8-14 { 875 1312 1750	3591-14CN875 3591-14CN1312 3591-14CN1750
5/16-18 { 312 469 625	1185-5CN312 1185-5CN469 1185-5CN625	1-1/4-7 { 1250 1875 2500	1185-20CN1250 1185-20CN1875 1185-20CN2500	5/16-18 { 312 469 625	3585-5CN312 3585-5CN469 3585-5CN625	1-8 { 1000 1500 2000	3585-16CN1000 3585-16CN1500 3585-16CN2000
5/16-24 { 312 469 625	1191-5CN312 1191-5CN469 1191-5CN625	1-1/4-12 { 1250 1875 2500	1191-20CN1250 1191-20CN1875 1191-20CN2500			1-14 { 1000 1500 2000	3591-16CN1000 3591-16CN1500 3591-16CN2000
3/8-16 { 375 562 750	1185-6CN375 1185-6CN562 1185-6CN750	1-3/8-6 { 1375 2062 2750	1185-22CN1375 1185-22CN2062 1185-22CN2750			1-12 { 1000 1500 2000	3591-161CN1000 3591-161CN1500 3591-161CN2000
3/8-24 { 375 562 750	1191-6CN375 1191-6CN562 1191-6CN750	1-3/8-12 { 1375 2062 2750	1191-22CN1375 1191-22CN2062 1191-22CN2750				
7/16-14 { 438 656 875	1185-7CN438 1185-7CN656 1185-7CN875	1-1/2-6 { 1500 2250 3000	1185-24CN1500 1185-24CN2250 1185-24CN3000				
7/16-20 { 438 656 875	1191-7CN438 1191-7CN656 1191-7CN875	1-1/2-12 { 1500 2250 3000	1191-24CN1500 1191-24CN2250 1191-24CN3000				



BULK Inserts

FREE RUNNING – METRIC

Size + Length	Part No.	Size + Length	Part No.	Size + Length	Part No.
M2.2x0.45 { 022 033 044	1084-2.2CN022 1084-2.2CN033 1084-2.2CN044	M18X1.5 { 180 270 360	3745-18CN180 3745-18CN270 3745-18CN360	M14x2 { 140 210 280	4184-14CN140 4184-14CN210 4184-14CN280
M2.5x0.45 { 025 038 050	1084-2.5CN025 1084-2.5CN038 1084-2.5CN050	M20X2.5 { 200 300 400	1084-20CN200 1084-20CN300 1084-20CN400	M14X1.5 { 140 210 280	5145-14CN140 5145-14CN210 5145-14CN280
M3x0.5 { 030 045 060	1084-3CN030 1084-3CN045 1084-3CN060	M22X2.5 { 220 330 440	1084-22CN220 1084-22CN330 1084-22CN440	M16X2 { 160 240 320	4184-16CN160 4184-16CN240 4184-16CN320
M3.5x0.6 { 035 053 070	1084-3.5CN035 1084-3.5CN053 1084-3.5CN070	M24X3 { 240 360 480	1084-24CN240 1084-24CN360 1084-24CN480	M16X1.5 { 160 240 320	5145-16CN160 5145-16CN240 5145-16CN320
M4x0.7 { 040 060 080	1084-4CN040 1084-4CN060 1084-4CN080	SCREW-LOCK – METRIC		M18X2.5 { 180 270 360	4184-18CN180 4184-18CN270 4184-18CN360
M5x0.8 { 050 075 100	1084-5CN050 1084-5CN075 1084-5CN100	Size + Length	Part No.	M18X1.5 { 180 270 360	5145-18CN180 5145-18CN270 5145-18CN360
M6x1 { 060 090 120	1084-6CN060 1084-6CN090 1084-6CN120	M2.2x0.45 { 022 033 044	4184-2.2CN022 4184-2.2CN033 4184-2.2CN044	M20X2.5 { 200 300 400	4184-20CN200 4184-20CN300 4184-20CN400
M7x1 { 070 105 140	1084-7CN070 1084-7CN105 1084-7CN140	M2.5x0.45 { 025 038 050	4184-2.5CN025 4184-2.5CN038 4184-2.5CN050	M22X2.5 { 220 330 440	4184-22CN220 4184-22CN330 4184-22CN440
M8x1.25 { 080 120 160	1084-8CN080 1084-8CN120 1084-8CN160	M3x0.5 { 030 045 060	4184-3CN030 4184-3CN045 4184-3CN060	M24x3 { 240 360 480	4184-24CN240 4184-24CN360 4184-24CN480
M8x1 { 080 120 160	4255-8CN080 4255-8CN120 4255-8CN160	M3.5x0.6 { 035 053 070	4184-3.5CN035 4184-3.5CN053 4184-3.5CN070		
M10x1.5 { 100 150 200	1084-10CN100 1084-10CN150 1084-10CN200	M4x0.7 { 040 060 080	4184-4CN040 4184-4CN060 4184-4CN080		
M10x1 { 100 150 200	4255-10CN100 4255-10CN150 4255-10CN200	M5x0.8 { 050 075 100	4184-5CN050 4184-5CN075 4184-5CN100		
M10x1.25 { 100 150 200	4649-10CN100 4649-10CN150 4649-10CN200	M6x1 { 060 090 120	4184-6CN060 4184-6CN090 4184-6CN120		
M12x1.75 { 120 180 240	1084-12CN120 1084-12CN180 1084-12CN240	M7x1 { 070 105 140	4184-7CN070 4184-7CN105 4184-7CN140		
M12x1.5 { 120 180 240	3745-12CN120 3745-12CN180 3745-12CN240	M8x1.25 { 080 120 160	4184-8CN080 4184-8CN120 4184-8CN160		
M12x1.25 { 120 180 240	4649-12CN120 4649-12CN180 4649-12CN240	M8x1 { 080 120 160	5255-8CN080 5255-8CN120 5255-8CN160		
M14x2 { 140 210 280	1084-14CN140 1084-14CN210 1084-14CN280	M10x1.5 { 100 150 200	4184-10CN100 4184-10CN150 4184-10CN200		
M14X1.5 { 140 210 280	3745-14CN140 3745-14CN210 3745-14CN280	M10x1 { 100 150 200	5255-10CN100 5255-10CN150 5255-10CN200		
M16X2 { 160 240 320	1084-16CN160 1084-16CN240 1084-16CN320	M10x1.25 { 100 150 200	5649-10CN100 5649-10CN150 5649-10CN200		
M16X1.5 { 160 240 320	3745-16CN160 3745-16CN240 3745-16CN320	M12x1.75 { 120 180 240	4184-12CN120 4184-12CN180 4184-12CN240		
M18X2.5 { 180 270 360	1084-18CN180 1084-18CN270 1084-18CN360	M12x1.5 { 120 180 240	5145-12CN120 5145-12CN180 5145-12CN240		
		M12x1.25 { 120 180 240	5649-12CN120 5649-12CN180 5649-12CN240		

Heli-Coil Stainless Steel inserts are available in bulk for higher quantity applications such as re-building or remanufacture. Each size comes in three different lengths:

SHORT (One times the diameter of the bolt or screw) – for short thread engagement applications.

MEDIUM (1-1/2 times the diameter of the bolt or screw) – provides sufficient strength in most applications.

LONG (Two times the diameter of the bolt or screw) – provides higher strength in critical applications, (especially in magnesium).

SPARK PLUG

Thread Size	Reach	Insert No.
10-1.0mm	1/2"	474-4
12-1.25mm	1/2"	482-1
12-1.25mm	3/4"	482-2
	3/8"	512
	7/16"	513
14-1.25mm	1/2"	513-13
	3/4"	513-10
	.472	513-20
18-1.50mm	1/2"	514-6
7/18-18	1/2" & 5/8"	518-12
	Short	5326-14S
M14x1.215	Normal	5326-14N
	Long	5326-14L

PIPE THREAD

(for Taper Pipe Threads)

Nominal Thread Size	Part Number
1/8-27	327-2
1/4-18	327-4
3/8-18	327-6
1/2-14	327-8
3/4-14	327-12
1-11-1/2	327-16



HELI-COIL STI Taps

Straight flute taps, available in both plug style and bottoming style, are widely used for general hand and machine tapping operations.

PLUG STYLE (4 thread chamfer): Used in thru holes and in blind holes that allow for ample chip clearance. They are easier starting and require less tapping torque than bottoming taps.

BOTTOMING STYLE (2 thread chamfer): Used in blind holes drilled to a minimum depth that require threads close to the bottom of the hole.



INCH SERIES

Nominal Thread Size	Plug Style Part No.	Bottoming Style Part No.
UNIFIED COARSE		
2-56	02CPB	02CBB
3-48	03CPB	03CBB
4-40	04CPB	04CBB
5-40	05CPB	05CBB
6-32	06CPB	06CBB
8-32	2CPB	2CBB
10-24	3CPB	3CBB
12-24	1CPB	1CBB
1/4-20	4CPB	4CBB
5/16-18	5CPB	5CBB
3/8-16	6CPB	6CBB
7/16-14	7CPB	7CBB
1/2-13	8CPB	8CBB
9/16-12	187-9	4187-9
5/8-11	8187-10	10187-10
3/4-10	8187-12	10187-12
7/8-9	8187-14	10187-14
1-8	8187-16	10187-16
1-1/8-7	8187-18	10187-18
1-1/4-7	8187-20	10187-20
1-3/8-6	8181-22	10187-22
1-1/2-6	8187-24	10187-24
UNIFIED FINE		
3-56	03FPB	03FBB
4-48	04FPB	04FBB
6-40	06FPB	06FBB
8-36	2FPB	2FBB
10-32	3FPB	3FBB
1/4-28	4FPB	4FBB
5/16-24	5FPB	5FBB
3/8-24	6FPB	6FBB
7/16-20	7FPB	7FBB
1/2-20	8FPB	8FBB
9/16-18	38193-9	43193-9
5/8-18	8193-10	10193-10
3/4-16	8193-12	10193-12
7/8-14	8193-14	10193-14
1-14	8193-16	10193-16
1-12	8193-161	10193-161
1-1/8-12	8193-18	10193-18
1-1/4-12	8193-20	10193-20
1-3/8-12	8193-22	10193-22
1-1/2-12	8193-24	10193-24

METRIC SERIES

Nominal Thread Size	Plug Style Part No.	Bottoming Style Part No.
COARSE		
M2.2x0.45	2087-2.2	2093-2.2
M2.5x0.45	2087-2.5	2093-2.5
M3x0.5	2087-3	2093-3
M3.5x0.6	2087-3.5	2093-3.5
M4x0.7	2087-4	2093-4
M5x0.8	2087-5	2093-5
M6x1	2087-6	2093-6
M7x1	2087-7	2093-7
M8x1.25	2087-8	2093-8
M10x1.5	2087-10	2093-10
M12x1.75	2087-12	2093-12
M14x2	2087-14	2093-14
M16x2	2087-16	2093-16
M18x2.5	2087-18	2093-18
M20x2.5	2087-20	2093-20
FINE		
M8X1	4984-8	4986-8
M10X1	4984-10	4986-10
M10X1.25	4944-10	4945-10
M12X1.25	4944-12	4945-12
M12X1.5	4976-12	4977-12
M14X1.5	4976-14	4977-14
M16X1.5	4976-16	4977-16
M18X1.5	4976-18	4977-18

SPARK PLUG TAPS

Thread Size	Reach	Tap Part No.
10-1.0mm	1/2"	1030-10
12-1.25mm	1/2"	1030-12
12-1.25mm	3/4"	1030-12
14-1.25mm	3/8"	1030-14
	7/16"	
	1/2"	
	3/4"	
18-1.50mm	1/2"	1030-18
	7/8-18	1/2"
7/8-18	5/8"	549

PIPE THREAD TAPS (for Taper Pipe Threads)

Nominal Thread Size	Part No.	Nominal Thread Size	Part No.
1/8-27	328-2	1/2-14	328-8
1/4-18	328-4	3/4-14	328-12
3/8-18	328-6	1-11-1/2	328-16