

AccuBird®

- (D)** **Elektro-mechanisches Blindnietgerät**
Betriebsanleitung mit Ersatzteilliste
- (GB)** **Battery Powered Riveting Tool**
Operating Manual with Spare Parts List
- (F)** **Riveteuse électro-mécanique**
Mode d'emploi avec pièces de rechange
- (E)** **Remachadora eléctrica**
Instrucciones de manejo con lista de repuestos
- (I)** **Rivettatrice elettrica a batteria**
Manuale per l'uso e la manutenzione ed elenco parti di ricambio
- (NL)** **Elektro mechanisch blindklinkpistool**
Bedienings- en onderhouds handleiding met onderdelenlijst
- (DK)** **Elektro-mekanisk blindnietapparat**
Betjeningsvejledning med reservedelsliste
- (S)** **Elektro-mekanisk blindnietpistol**
Bruksanvisning med reservedelslista
- (N)** **Elektro mekanisk blindnaglepistol**
Bruksanvisning med reservedelliste
- (FIN)** **Sähkömekaaninen sokkoniihtauslaite**
Käyttöohje ja varaosalista
- (P)** **Equipamento eletromecânico de rebitegem cega**
Instrução de serviço com lista de peças de reposição
- (PL)** **Nitownica akumulatorowa**
Instrukcja obsługi wraz ze spisem części zamiennych
- (H)** **Elektro-mechanikus szegecsúzó készülék**
Üzemeltetési utasítás,alkatrészlistával
- (CZ)** **Elektro-mechanický nýtovací přístroj**
Návod k obsluze s listinou náhradních dílu



GESIPA Blindniettechnik GmbH
Nordendstraße 13-39
D-64546 Mörfelden-Walldorf
T +49 (0) 6105 962 0
F +49 (0) 6105 962 287
info@gesipa.com
www.gesipa.com

GESIPA®

Contents	page
1. Riveting Tool	
1.1. Work Capacity	9
1.2. Equipment/Accessories	9
1.3. Technical Data	9
1.4. Nosepiece table	10
1.5. Safety instructions	10
1.6. Starting procedure	11
1.7. Mode of operation	11
1.8. Maintenance	11
2. Charger and battery	
2.1. Technical characteristics	11
2.1.1. Battery charger	11
2.1.2. Battery	11
2.2. Safety instructions	11
2.2.1. Battery Charger	11
2.2.2. Battery	12
2.3. Charging procedure	12
2.4. Battery handling	12
2.5. Environmental Protection	12
3. Trouble Shooting	13
4. Warranty	14
5. CE Conformity declaration	14
6. Spare parts drawing	88
7. Spare parts list	88

1. Riveting Tool

1.1. Work Capacity

Blind Rivets up to 5 mm (3/16") dia. all materials
BULB-TITE® Rivets 4; 5,2 and 6,3 mm dia. Aluminium
and Steel.

BULB-TITE® Series Numbers: RV 6601 RV 6602
RV 6604 RV 6606
RV 6671 RV 6676

1.2. Equipment/Accessories

Nosepiece: 17/32 in working position
17/27, 17/29 and 17/24
in nosepiece-holder
Wrench: SW 12 (cover for nosepiece-
holder)

Suspension loop: concealed in housing
Battery (quick-charge): 14,4 Volt

1.3. Technical Data

Weight: 2,2 kg (4,85 lbs). with battery
Stroke: 20 mm (.787")
Drive Unit: 14,4 V direct current motor
Traction Power: 8.500 N (1.900 lbs.)
Noise emission: L_{PA} 78,5 dB
Vibrations: < 2,5 m/s²

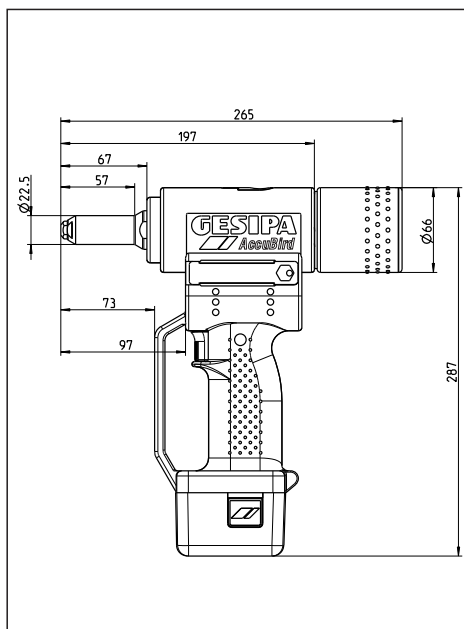



1.4. Nosepiece table

Rivet Ø (mm)	Rivet body material	Nosepiece	Part.-No.
2,4	Alum	17/18*	725 2075
3,2	CAP-Alum, CAP-CU	17/18*	725 2075
3 and 3,2	Alum, CU, Steel, Stainless Steel, Stinox, Alum/Alum, PG-Alum, PG-Steel, PG-Stainless Steel	17/24	725 1583
4	Alum, CU, CAP-Alum, CAP-CU	17/24	725 1583
4	Steel, Alum/Alum, PG-Alum	17/27	725 2040
4	Stainless Steel, Stinox, PG-Steel, PG-Stainless Steel	17/29	725 2059
4,8 and 5	Alum, CAP-Alum, CAP-CU, PG-Alum	17/29	725 2059
4,8 and 5	Steel, Alum/Alum	17/32	725 2067
4,8 and 5	PG-Steel, PG-Stainless Steel, G-Bulb	17/36*	725 2083
6	Alum	17/36*	725 2083

BULB-TITE Ø (mm)	Rivet body material	Nosepiece	Part.-No.
4	Alum/Alum	17/26 BT*	725 2202
5,2	Alum/Alum	17/32 BT*	725 2210
6,3	Alum/Alum, Steel/Steel	17/42 BT**	725 2229

BULB-TITE Ø (mm)	Rivet body material	Jaw Pusher BT	Part.-No.	Jaws BT	Part.-No.
6,3	Alum/Alum, Steel/Steel	54**	725 2245	55**	715 1527

* available as special accessories. Elongated nosepieces and other special nosepieces are available upon request.

** Also available as a complete set (# 50) part no. 725 9290.

1.5. Safety instructions

Blind rivet setting tool AccuBird®



Caution:

Following safety rules must be followed for adequate protection against electrical shock, injuries or fire hazards:

- The riveting tool should be used exclusively to set blind rivets.
- Do not overload the tool; Work within the prescribed work capacity.
- Do not expose the tool to humidity or rain, do not operate the tool close to inflammable substances or gases: **Risk of explosion!**
- Ensure that the battery is properly secured in the tool handgrip.
- Remove the battery when the tool is not in use and for repair/servicing operations.
- Do not use the tool as a hammer.
- When not in use, keep the tool in a dry closed room, out of reach of children.
- When working with the tool, always carry protection goggles. Personal protection like clothes, gloves, safety helmet, non slipping shoes, ear protectors and protection against fall are highly recommended.
- The air inlets for the engine should not be obstructed. Do not introduce anything into them.
- When depositing the tool, make sure that it cannot fall down.
- Use only genuine spare parts for repair.
- Repair work must be carried out by skilled personal. In case of doubt, always send back the tool to the manufacturer!
- Do not use the tool outside of riveting holes. The blind rivet could be ejected from the tool. Never turn the tool towards yourself or towards another person.

- Part N° 39 (mandrel container) must be mounted on the tool during operation.

1.6. Starting Procedure

- Engage fully charged battery in correct position into housing.
- Select correct nosepiece (according to table 1.4.) and screw into head.
- Attention: Do not cover the vent holes and do not obstruct the vent holes.

1.7. Operating Procedure

- Depressing the switch starts the operation.
- When releasing the switch the jaw assembly returns to the start position automatically.
- Eject the spent mandrel by tilting to the rear into the spent mandrel container or to the front through the nosepiece.
- The riveting tool is equipped with an overload protection. In the event of an overload the operation will be stopped and the red light shows. Release the switch and the assembly will return to the start position.
- The battery will keep the power relatively stable until a sudden drop-off, resulting in only 2-3 more rivets being set. The jaw mechanism will automatically return to the starting position when the switch has been released.

1.8. Maintenance

The maintenance of the riveting tool is limited to the complete jaw assembly:

- Remove the battery (part no. 40) from tool housing.
- Unscrew the head (part no. 13) from the tool and clean. Look for deposits in the head.
- Unscrew the jaw housing (part no. 12) from the coupler (part no. 7) using an open end wrench SW 17.
- Take out the jaws (part no. 11), clean and lubricate or replace them if worn.
- Re-assemble in reverse order ensuring that all parts are tightened!



2. Charger and battery

2.1. Technical characteristics

2.1.1. Battery charger

Type:	12355/12356
Input voltage:	220-240VAC/50-60Hz
Output voltage:	14,4VDC
Output current:	1,5A max.
Weight:	0,6kg

2.1.2. Battery

Nominal voltage:	14,4VDC
Number of cells:	4/8
Cell:	Li-Ion
Capacity:	1,3Ah/2,6Ah
Weight:	0,35/0,5kg

2.2. Safety Instructions

2.2.1. Battery charger

Caution:

Following safety rules must be followed for adequate protection against electrical shock, injuries or fire hazards:

- The charger must be exclusively used to charge GESIPA batteries.
- Check regularly cord, plug and device and have it fixed by skilled personal when damaged.
- Use exclusively genuine plugs and cords and genuine spare parts for repair.
- Never use the charger in humid or wet environment, or close to inflammable substances or gases: **Explosion hazard!**
- Take the charger out of its package before use. Insert the battery in the right way (pole+ to pole+) into the charger bay. Insertion should take place without noticeable effort.
- Never try to charge non rechargeable batteries.
- Store the charger in a dry closed room, out of reach of children.
- Never insert metallic parts into the charging bay: Short circuit hazard.
- When the charger is wall-mounted, make sure that the inserted battery cannot fall down.



GB

- Do not operate this battery charger at altitudes exceeding 2.000 meter above sea level.
- This battery charger should not be operated neither by physically disabled or mentally affected people, nor by untrained or unskilled people.



2.2.2. Battery

Caution:

Following safety rules must be followed for adequate protection against electrical shock, injuries or fire hazards:

- Never try to charge a damaged battery.
- Do not insert a dirty or wet battery into the charger.
- Never throw batteries into the waste, into fire or into water.
- Do not charge a battery when the environment temperature is below 0°C.

2.3. Charging procedure

- Charge only GESIPA batteries when the environment temperature is between 0°C and 40°C.
- Take the charger out of its package and connect to mains. Check the input voltage on the type label before connecting.
- Insert the battery in the right way (pole+ to pole+) into the charger bay. Insertion should take place without noticeable effort.
- The charging operation starts automatically when the battery is inserted into the charging bay.

Function lights:

- Steady green: Battery is charged,
preserv.charge in process
- Blinking green: Charging
- Steady red: Charging temperature out of range
(battery too hot or too cold)
- Blinking red: Battery is defective

Typical charging cycles:

Type	Part Number	Charging cycle*
1,3 Ah	725 1045	approx. 50 min
2,6 Ah	725 1049	approx. 100 min

*charging cycles may vary according to the rest capacity and the battery temperature.

2.4. Battery handling

- Use only cold batteries to obtain optimum charging.
- The GESIPA batteries can be charged approx. 1.000 times and reaches its maximum capacity only after several charging cycles.
- Do not insert the battery into the charger after each use, but wait until the battery is fully discharged (tool cannot set the rivet).
- Recharge the battery after a long period of inactivity.
- Battery autonomy becoming shorter despite of proper recharging means that the battery must be replaced.
- Keep the battery in dry and warm rooms. The optimum operating temperature range is 10°C to 50°C.

2.5. Environmental protection

If batteries have to be replaced, the following instructions should be followed:



- Bring back discarded batteries to your GESIPA agent or to GESIPA for recycling.
- Never throw away discarded batteries into waste, fire or water.

3. Trouble Shooting

3.1. Blind rivet cannot be set

Causes

- Battery empty
- Jaws dirty or worn
- Jaw assembly loose
- Jaw pusher spring weak
- When trigger is pressed, non-function (red light)

Remedy

charge, if necessary replace
 clean and lubricate or replace (see 1.8.)
 tighten (see 1.8.)
 replace
 see par. 3.3.

3.2. No spent mandrel discharge

Causes

- Wrong nosepiece
- Nosepiece worn
- Mandrel jammed in jaws

- Dirt inside head
- Spent mandrel container full
- Mandrel guide tube blocked

Remedy

exchange according to table 1.4.
 replace
 loosen the mandrel, clean jaws and jaw housing, lubricate surface, respectively
 replace jaws (see 1.8.)
 clean (see 1.8.)
 take off and empty
 remove clogged mandrels and check for free ejection (see 1.8.)

3.3. Red light indicates faults

3.3.1. when trigger is pressed

Causes

- Tool not in front position

Remedy

release the trigger

3.3.2. while pulling the rivet

Causes

- Overloading
- Overheating of electronic control
- Battery empty

Remedy

check working capacity according to table 1.4.
 allow the tool to cool off in air
 charge or replace

3.3.3. after releasing the trigger

Causes

- Jaw assembly does not reach the front position

Remedy

screw on the jaw assembly tightly
 (see 1.8. and 3.2.)

3.3.4. Note

- In case of trouble indicated by the red light, which can't be eliminated as described above, the tool has to be repaired by trained personnel only or to be returned to the distributor or the manufacturer.

GB

4. Warranty

This riveting tool has a 24 months warranty from the day of delivery (to be proved by invoice or delivery note). Damage caused by common wearing, overloading or improper handling are excluded from the warranty.

Damages caused by material or manufacturing faults will be covered by this warranty and will be repaired or replaced at no cost. Claims can only be accepted if the **complete** riveting tool (not stripped) is returned to the distributor or **GESIPA**.

5. CE Conformity declaration

We hereby declare under our sole responsibility that these products meet following standards and directives:

- EN 50260
- EN 60335
- 2006/42/EG
- 2006/95/EG
- 2004/108/EG



H.U. Harder
(Safety Officer)

6. **(D)** Ersatzteile **(NL)** Onderdelen **(P)** Peças sobressalentes
(GB) Spare Parts **(DK)** Reservedele **(PL)** Części zamienne
(F) Pièces détachées **(S)** Reservdelsar **(H)** Alkatrészek
(E) Piezas de recambio **(N)** Reservedeler **(CZ)** Náhradní díly
(I) Lista dei pezzi di ricambio **(FIN)** Varaosaluettelo

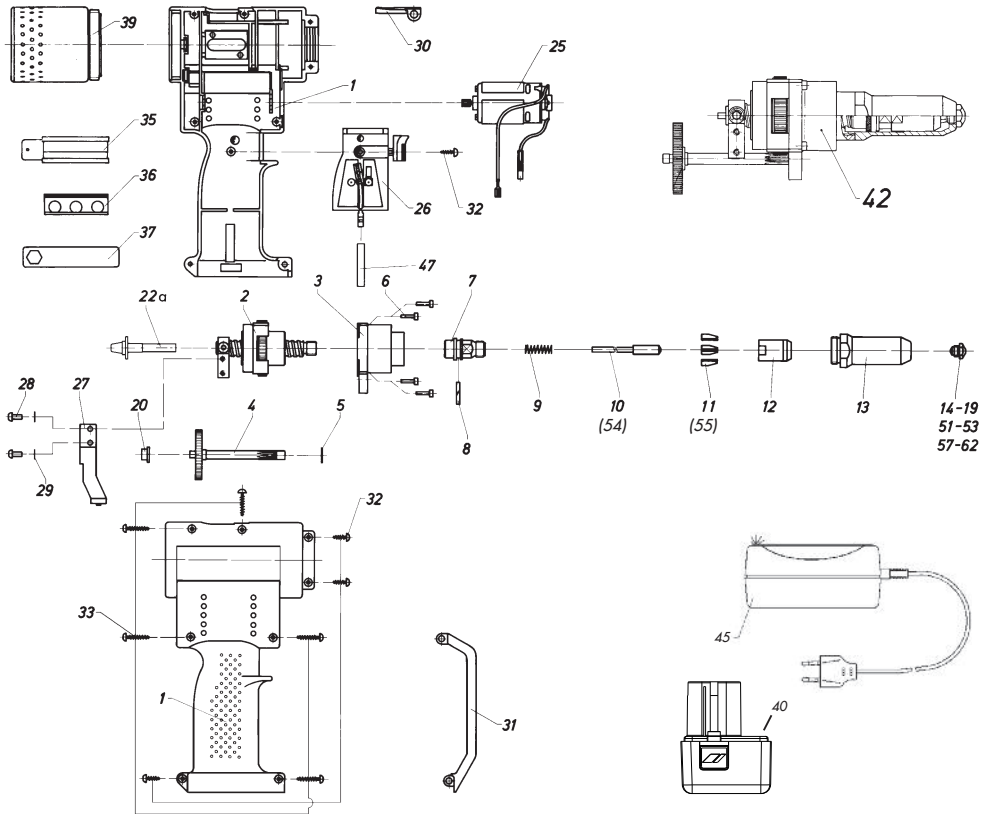

7.

1	725 9274	
2	725 9142	
3	725 9185	
4	725 9193	
5	725 1753	
6	725 1982	
7	725 1605	
8	725 1745	
9•	717 9693	
10•	725 1621	
11•	725 1613	
12	713 2123	
13	725 1591	
14	725 2075	17/18
15	725 1583	17/24
16	725 2040	17/27
17	725 2059	17/29

18	725 2067	17/32
19	725 2083	17/36
20	725 1893	
22 a	725 1521	
25	725 9223	
26	725 1850	
27	725 9266	
28	725 1990	
29	725 2008	
30	725 1559	
31	725 1540	
32	725 2032	
33	725 2024	
35	725 1567	
36	725 2091	
37	725 1834	
39	725 9282	

40	725 1045	
42	725 9134	
45	725 1134	
46	725 2555	
47	725 5066	
50	725 9290	
51	725 2202	17/26 BT
52	725 2210	17/32 BT
53	725 2229	17/42 BT
54•	725 2245	
55•	715 1527	
57•	725 4078	17/18 R
58•	725 4086	17/24 R
59•	725 4094	17/27 R
60•	725 4108	17/29 R
61•	725 4116	17/32 R
62•	725 4124	17/36 R